

## ABSOLUTE ROTARY ENCODER SUCONET



### Main Features

- Compact and heavy-duty industrial model
- Interface: SUCOnet K1
- Housing: 58 mm Ø
- Shaft: 6 or 10 mm Ø
- Resolution: max. 25 Bit = 33,554,432 steps over 4,096 revolutions
- Code: Binary

### Programmable Parameters

- Direction of rotation (complement)
- Total resolution
- Number of revolutions
- Preset value
- Gear factor

### Mechanical Structure

- Flange and housing of Aluminum
- Shaft of stainless steel
- Precision ball bearings with sealing or cover rings
- Code disc made of unbreakable and durable plastic

### Electrical Features

- Status indication with two LEDs in the connection cap
- Parameters are saved in a non-volatile memory
- 400 million write cycles
- Temperature insensitive IR-opto-receiver array
- Polarity inversion protection
- Over-voltage-peak protection

## ABSOLUTE ROTARY ENCODER SUCONET

### Technical Data

#### Electrical Data

Supply voltage	10 - 30 V DC
Power consumption	Max. 3.5 Watt
EMC	EN 50081-2, EN 61000-6-2
Bus connection	Line-driver according to RS 485 Galvanically isolated by opto-couplers
Transmission rate	187.5 kBaud
Accuracy of division	$\pm \frac{1}{2}$ LSB
Step frequency LSB	Max. 100 kHz (valid code)
Electrical lifetime	$> 10^5$ h
Device addressing	Programmable by rotary switches in connection cap

#### Mechanical Data

Housing	Aluminum	
Lifetime	$> 10^5$ h at 1,000 rpm	
Inertia of rotor	$\approx 50 \text{ gcm}^2$	
RPM	Max. 6,000 (continuously)	
Shock (EN 60068-2-27)	$\leq 30 \text{ g}$ (halfsine, 11 ms)	
Permanent shock (EN 60028-2-29)	$\leq 10 \text{ g}$ (halfsine, 16 ms)	
Vibration (EN 60068-2-6)	$\leq 10 \text{ g}$ (10 Hz ... 1,000 Hz)	
Weight, single-turn	$\approx 500 \text{ g}$	
Weight, multi-turn	$\approx 700 \text{ g}$	
Shaft loading	Axial 20 N, radial 110 N	
Friction torque	$\leq 5 \text{ Ncm}$	
<b>Flange</b>	<b>Synchro (Y)</b>	<b>Clamp (F), synchro (Z)</b>
Shaft diameter	6 mm	10 mm
Shaft length	10 mm	20 mm

#### Environmental Conditions

Operating temperature	0 ... + 70 °C	
Storage temperature	- 40 ... + 85 °C	
Humidity	98 % (without liquid state)	
Protection class (EN 60529)		
Casing side	IP 65	
Shaft side	IP 65*	(* up to 0.5 bar)

## ABSOLUTE ROTARY ENCODER SUCONET

### Interface

#### Installation

The rotary encoder is connected by two or three cables depending on whether the power supply is integrated into the bus cable or connected separately. If the power supply is integrated into the bus cable, one of the cable glands can be fitted with a plug. The cable glands are suitable for cable diameters from 5.5 up to 9 mm.

Termination resistors are integrated in the connection cap. These must be switched on if the encoder is connected at the end or the beginning of the bus.

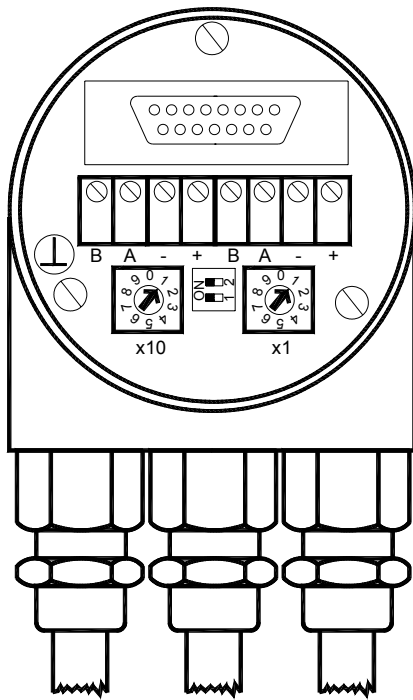

Device X

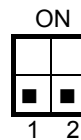

last device

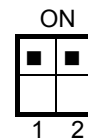

The settings of the SUCOnet device address is done by user-friendly rotary switches in the connection cap. Allowed addresses are between 2 and 30, and each can only be used once (attention, the address 1 is reserved for the master). The connection cap can easily be opened for installation by removing the two cap screws.

A detailed user manual can be ordered from FRABA or downloaded from our homepage ([www.posital.de](http://www.posital.de)).

The connection cap is provided with two LEDs on the backside, which optically represent the device status. This can be very useful for installing and setting-up the encoder.

### ABSOLUTE ROTARY ENCODER SUCONET

#### Programmable Parameters

The SUCOnet absolute rotary encoder can be programmed directly via the bus. The following parameters can be set (refer to the user manual):

Code sequence	As an operating parameter the code sequence (complement) can be programmed. This parameter determines whether the output code increases or decreases when the axis is turned clockwise.
Number of revolutions	The encoder calculates the gearing factor by referring the desired number of steps to this number of revolutions.
Number of physical steps	The encoder calculates the gearing factor by referring the desired number of steps to this number of physical position steps.
Desired number of steps	Number of steps which the encoder should output in a certain position range (either number of revolutions or number of physical steps).
Total resolution	This parameter is used to program the maximum output value. After reaching this value, the output will start from zero again. This value must not exceed the total resolution of the absolute rotary encoder. If the encoder is used in a continuous measuring application, certain rules for the setting of this parameter must be followed. These rules are outlined in the manual.
Preset value	The preset value is the desired output value for the actual position of the axis. The actual output value will be set to this preset value.
Direct input of the gearing factor	An input value of 01 00 00 00 (hex) corresponds to a gearing factor of 1. For example a gearing factor of 0.5 is achieved by input of 00 80 00 00 (hex).
Zero point displacement	This parameter sets the zero point of the output in relation to the physical zero point position of the encoder (same functionality as preset value).

## ABSOLUTE ROTARY ENCODER SUCONET

### Mechanical Drawings

#### Synchro Flange (Y, Z)

The only difference between the Y- and Z-Flange is the shaft size (6 or 10 mm, refer to the table besides).

	d / mm	l / mm
Y-Flange	6 <sub>f6</sub>	10
Z-Flange	10 <sub>h8</sub>	20

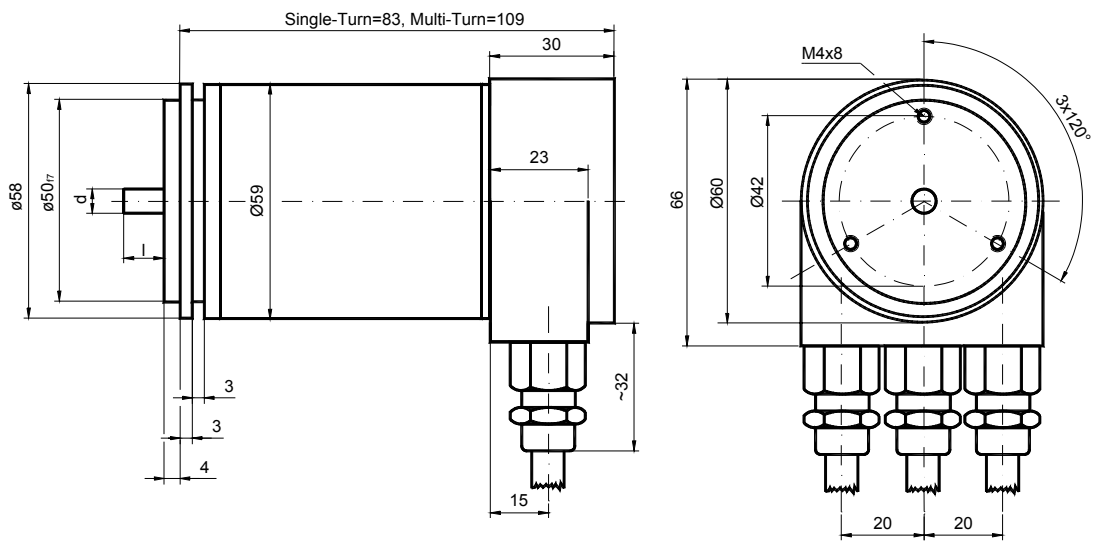

#### Clamp Flange (F)

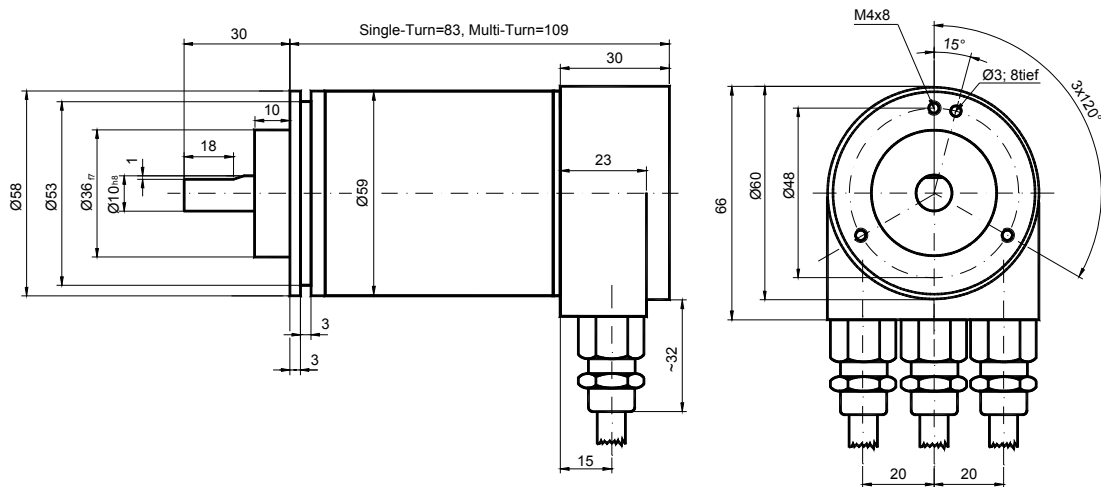

### ABSOLUTE ROTARY ENCODER SUCONET

#### Models/Ordering Description

Description	Type Key								
Absolute rotary encoder	<b>AWC</b>	<b>58</b>	...	.....	.	<b>B</b>	<b>A1</b>	<b>SU</b>	<b>3PG</b>
Diameter in mm									
Steps per revolution	4096	<b>12</b>							
	8192	13							
No. of revolutions	1		<b>1</b>						
	4096		<b>4096</b>						
Flange	Clamp Flange (shaft = 10 mm Ø)					<b>F</b>			
	Synchro Flange (shaft = 6 mm Ø)					<b>Y</b>			
	Synchro Flange (shaft = 10 mm Ø)					<b>Z</b>			
Code	Binary					<b>B</b>			
Version							<b>A1</b>		
Interface	SUCOnet K1 programmable							<b>SU</b>	
Options	Without							<b>0</b>	
	Shaft sealing (not possible for Z-Flange)							<b>W</b>	
	Stainless steel configuration (Flange, housing)							<b>Q</b>	
Connection	Connection Cap								<b>3PG</b>
	Has to be ordered separately – see accessories								

Further models on request.

#### Accessories and Documentation

Description		Type
Connection cap	T-coupling-functionality with integrated address setting is necessary to use the encoder	
	Standard	AH 58-A1SU-3PG
	Stainless steel configuration	AH 58-A1SU-3PG-VA
Connection cap "2M20" - special version -	Same function as standard cap but only two cable glands for cable diameters from 9 up to 13 mm	AH 58-A1SU-2M20
Shaft coupling	Drilling: 10 mm	GS 10
	Drilling: 6 mm	GS 06
Clamp disc	4 pcs. / AWC	SP 15
Clamp ring	2 pcs. / AWC	SP H
User manual *	Installation and configuration manual, English	UME-SN

\* Can be downloaded free of charge from our homepage [www.posita1.de](http://www.posita1.de).

We do not assume responsibility for technical inaccuracies or omissions. Specifications are subject to change without notice.