

### ABSOLUTE ROTARY ENCODER ETHERNET-TCP/IP



#### Main Features

- Compact and heavy duty industrial model
- Communication via standard protocols
- Integrated web server
- Interface: Ethernet-TCP/IP
- Housing: 58 mm Ø
- Shaft: 6 or 10 mm Ø
- Resolution: max. 25 Bit = 33.554.432 steps over 4096 revolutions
- Code: Binary

#### Programmable Parameters

- Direction of rotation (complement)
- Output steps over number of revolutions
- Number of revolutions
- Preset value
- Output of velocity
- Output of cam functions
- Output of temperature
- Network- and e-mail- parameters

#### Mechanical Structure

- Flange and housing, Aluminum and Brass respectively
- Stainless steel shaft
- Precision ball bearings with sealing or cover rings
- Code disc made of durable and unbreakable plastic
- Robust electrical connection in IP 67

#### Electrical Features

- Status indication with two LEDs
- Temperature insensitive IR-Opto-receiver-Array
- Polarity inversion protection
- Over-voltage-peak protection

### ABSOLUTE ROTARY ENCODER ETHERNET-TCP/IP

#### Technical Data

##### Electrical Data

Supply voltage	10 - 30 V DC (absolute limits)
Power consumption	max. 4 Watt
EMC	EN 50081-2, EN 61000-6-2
Bus connection	Ethernet
Transmission rate	10/100 MBit
Accuracy of division	$\pm \frac{1}{2}$ LSB
Step frequency LSB	Max. 100kHz (valid code)
Electrical lifetime	$> 10^5$ h
Device addressing	Programmable IP-Address and Network parameters

##### Mechanical Data

Housing	Aluminum	
Lifetime	$> 10^5$ h at 1000 rpm	
Inertia of rotor	$\approx 50$ gcm <sup>2</sup>	
RPM	Max. 6000 (continuously)	
Shock (EN 60068-2-27)	$\leq 30$ g (halfsine, 11 ms)	
Permanent shock (EN 60028-2-29)	$\leq 10$ g (halfsine, 16 ms)	
Vibration (EN 60068-2-6)	$\leq 10$ g (10 Hz ... 1000 Hz)	
Weight, Single-turn	$\approx 500$ g	
Weight, Multi-turn	$\approx 700$ g	
Shaft loading	axial 20 N, radial 110 N	
Friction torque	$\leq 5$ Ncm	
<b>Flange</b>	<b>Synchro (Y)</b>	<b>Clamp (F), synchro (Z)</b>
Shaft diameter	6 mm	10 mm
Shaft length	10 mm	20 mm

##### Environmental Conditions

Operating temperature	0 ... + 60 °C	
Storage temperature	- 40 ... + 85 °C	
Humidity	98 % (without liquid state)	
Protection class (EN 60529):		
Casing side	IP 67	
Shaft side	IP 65*	(* up to 0,5 bar)

### ABSOLUTE ROTARY ENCODER ETHERNET-TCP/IP

#### Interface

##### Protocols

The communication is based on Ethernet-TCP/IP at data rates of 100 Mbps or 10 Mbps. TCP/IP stacks are available in all common operating systems. A data exchange in heterogeneous networks is possible by using the IP protocol. The control system can change or read data and parameters by exchanging plaintext commands. A graphical user interface (GUI) and full documentation is provided on an integrated "micro web server" for a convenient configuration and diagnosis. Based on http, html and Java applets

the GUI and all documents can be displayed on all common web browsers. In addition to the encoder parameters all necessary network parameters, like the IP-address, can be set. All parameters are saved in a non volatile memory so that the configuration is available promptly after a restart. Another feature of the web server is the optional output of messages via the SMTP protocol. In this way parameters and diagnosis messages can be sent by e-mail.

IP	A data exchange in heterogeneous networks is possible by using the well known internet protocol "IP". The universal IP addressing simplifies the implementation of communication processes significantly.
TCP	Das TCP-Protocol assures an error free data transmission. For an enhanced real-time performance, the UDP protocol can be used alternatively.
http	Via http a common web browser can be used for read out, configuration and diagnosis of the encoder.
smtp	Via smtp protocol messages of the encoder can simply be sent by e-mail.

### ABSOLUTE ROTARY ENCODER ETHERNET-TCP/IP

#### Programmable Parameters

The encoder provides three modes of operation: position mode, velocity mode and cam mode. Within the position- and cam mode the sensor can be configured using different parameters. In this way the resolution and measurement range can be adapted to the application specific requirements.

Code sequence	The code sequence (complement) can be programmed as an operating parameter. This parameter determines whether the output code increases or decreases when the axis is turned clockwise.
Output steps over number of revolutions	This parameter defines the number of measuring steps over the number of revolutions described below.
Number of revolutions	This parameter determines the number of revolutions used to calculate the steps per revolution. For example: Total resolution=8, Revolutions=2, then the Steps per revolution will be equal to 4. This value must always be less than the total allowed revolutions (for a multi-turn, 4,096).
Preset value	The preset value is the desired output value for the actual position of the axis. The actual output value will be set to this preset value.
Velocity	Optionally, the current rotational velocity of the axis can be output in revolutions per minute.
Cam functions	Cam functions which are entirely programmable via the bus are integrated in the encoder. 8 different cams can be configured by adjusting their initial point and endpoint.

For configuration and diagnosis purposes the encoder provides the following website:

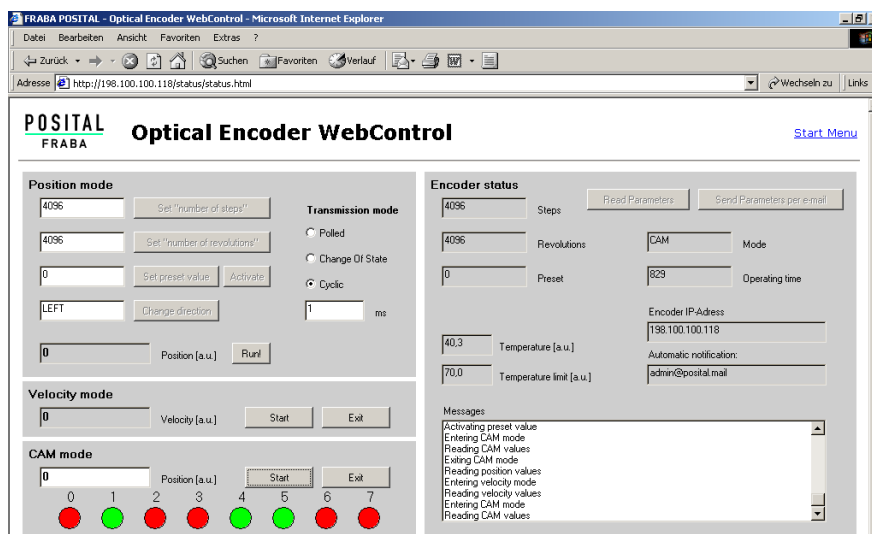

### ABSOLUTE ROTARY ENCODER ETHERNET-TCP/IP

#### Mechanical Drawings

##### Synchro Flange (Y,Z)

The only difference between the Y- and Z-Flange is the shaft size (6 or 10 mm, refer to the table besides).

	d [mm]	l [mm]
Y-Flange	6 <sub>f6</sub>	10
Z-Flange	10 <sub>h8</sub>	20

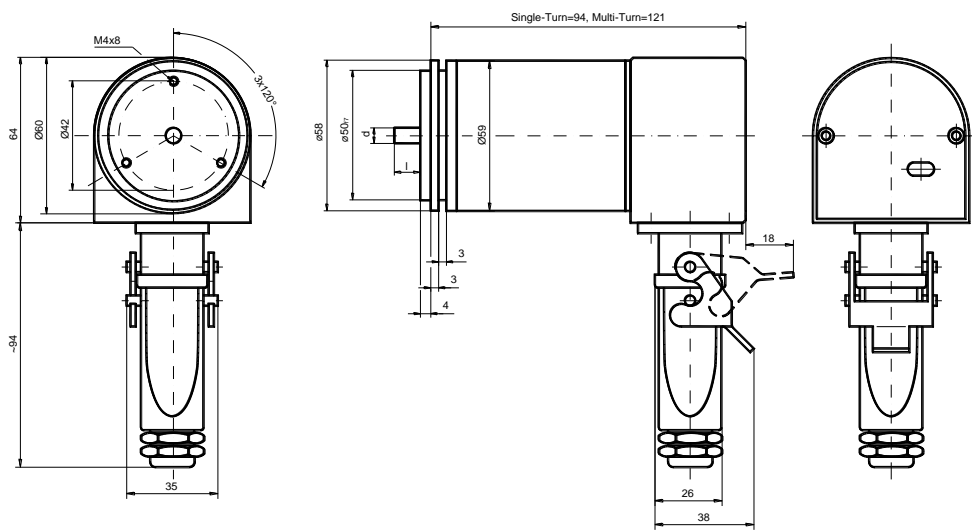

##### Clamp Flange (F)

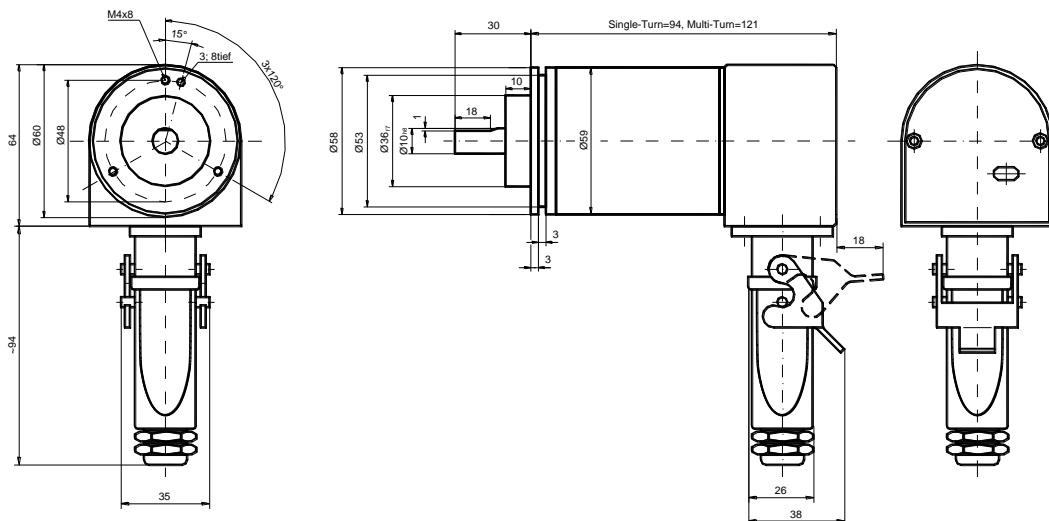

### ABSOLUTE ROTARY ENCODER ETHERNET-TCP/IP

#### Models/Ordering Description

Description	Type Key									
Absolute rotary encoder	<b>AWC</b>	<b>58</b>	...	...	...	<b>B</b>	<b>00</b>	<b>E1</b>	...	<b>HAW</b>
Diameter in mm										
Steps per revolution	4096	<b>12</b>								
	8192	13								
No. of revolutions	1	<b>1</b>								
	4096	<b>4096</b>								
Flange	Clamp Flange (Shaft = 10 mm Ø)		<b>F</b>							
	Synchro Flange (Shaft = 6 mm Ø)		<b>Y</b>							
	Synchro Flange (Shaft = 10 mm Ø)		<b>Z</b>							
Code	Binary		<b>B</b>							
Version			<b>00</b>							
Interface	Ethernet-TCP/IP		<b>E1</b>							
Options	Without		<b>0</b>							
	Shaft sealing (not possible for Z-Flange)		<b>W</b>							
	Stainless steel configuration (flange, housing)		<b>Q</b>							
Connection	Connector (IP 67)		<b>HAW</b>							

**Standard = bold**, further models on request

#### Accessories and Documentation

Description	Type	
Shaft coupling	Drilling: 10 mm	GS 10
	Drilling: 6 mm	GS 06
Clamp disc	4 pcs. / AWC	SP 15
Clamp ring	2 pcs. / AWC	SP H
User manual	Installation / configuration manual, English	UMD-E1
User manual	Installation / configuration manual, German	UME-E1

We do not assume responsibility for technical inaccuracies or omissions. Specifications are subject to change without notice.